

RXL 304

Bakery oven



MAGNIBERIA
EQUIPAMENTO E SERVIÇOS PARA HOTELARIA



Ref. 710534



TECHNICAL CHARACTERISTICS

Electric power 3100 W

Max temperature 250 °C

Weight 35 kg

Voltage 230 V-50/60 Hz

Connection single phase Shucko

Internal dimensions (W)450x(D)340x(H)345 mm

External dimensions (W)590x(D)675x(H)540 mm

Humidifier (ref. 710535)

Change door opening

EQUIPAMIENTO-FUNCIONES

- *Safety thermostat*
- *0-60 Minute timer*
- *Non-stop mode*
- *Standard equipment 4 perforated aluminium trays*

CAPACITY

4 trays 430x340

4 trays GN 2/3

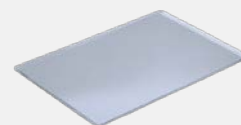

RXL 304

Specific accessories



MAGNIBERIA
EQUIPAMENTO E SERVIÇOS PARA HOTELARIA



RX 43/44 Stand

Ref. 710547



(W)590x(D)580x(H)850 mm

Wheels

Ref. 710286



Wheeled option

Fumes condenser kit

RX SERIES

Ref. 710551

(W)170x(D)70x(H)400 mm

RX H2O SERIES

Ref. 710552

(W)720x(D)85x(H)450 mm

RX DUO SERIES

Ref. 710553

(W)580x(D)120x(H)180 mm

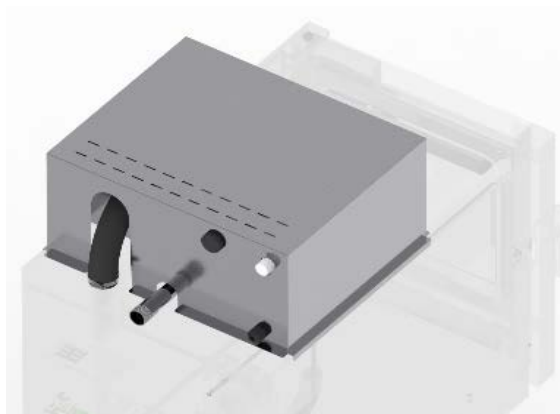

RX 43/34 Superposition kit

Ref. 710554



(W)640x(D)720x(H)40 mm

